

Safety and operating instructions

Petrol breakers

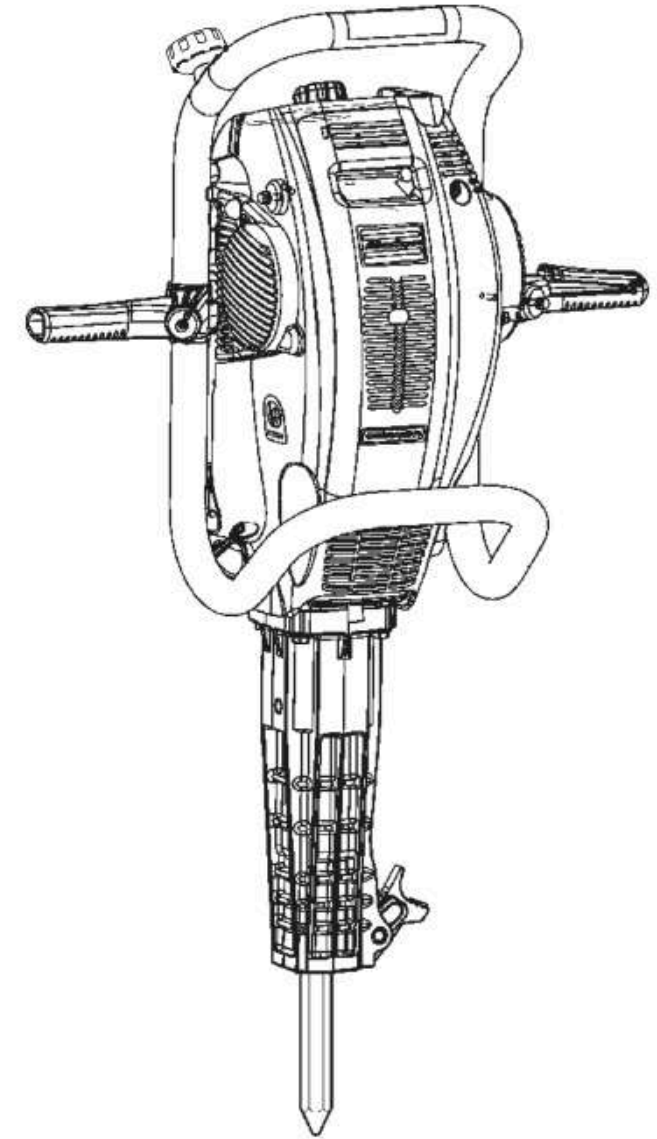

Contents

Introduction	5
About the Safety and operating instructions	5
Safety instructions	5
Safety signal words	5
Personal precautions and qualifications	5
Personal protective equipment	5
Drugs, alcohol or medication	5
Installation, precautions	6
Operation, precautions	6
Maintenance, precautions	10
Storage, precautions	10
Overview	11
Design and function	11
Main parts	11
Labels	11
Data plate	11
Noise level label	12
Overheating hazard label	12
Warning label	12
Emission compliance label	12
Transport	12
Installation	12
Fuel	12
Environmental petrol	12
Two-stroke oil	12
Mixing the petrol and oil	13
Filling	13
Working tool	14
Selecting the correct working tool	14
Narrow chisel	14
Moil point	14
Wide bladed chisel	14
Spiking tool	14
Checking for wear on the tool shank	14
Operation	15
Start and stop	15
Operating	15
When taking a break	17
Maintenance	17
Every day	17
Every month	18
Gearbox oil level check	18
Service	18
Repair	18
Replacing the starter cord	18
Troubleshooting	19
Storage	19
Disposal	20



Technical data	21
Products	21
Gearbox unit	21
Impact unit	21
Machine data	22
Noise and vibration declaration statement	23
Noise and vibration data	23
EC Declaration of Conformity	24
EU Declaration of Conformity	24



Introduction

Thank you for choosing a product from Atlas Copco. Since 1873, we have been committed to finding new and better ways of fulfilling our customers' needs. Through the years, we have developed innovative and ergonomic product designs that have helped customers improve and rationalize their daily work.

Atlas Copco has a strong global sales and service network, consisting of customer centers and distributors worldwide. Our experts are highly trained professionals with extensive product knowledge and application experience. In all corners of the world, we can offer product support and expertise to ensure that our customers can work at maximum efficiency at all times.

For more information please visit:

www.atlascopco.com

Atlas Copco Airpower
Boomsesteenweg 957
2610 Wilrijk
Belgium

About the Safety and operating instructions

The aim of the instructions is to provide you with knowledge of how to use the machine in an efficient, safe way. The instructions also give you advice and tell you how to perform regular maintenance on the machine.

Before using the machine for the first time you must read these instructions carefully and understand all of them.

Safety instructions

To reduce the risk of serious injury or death to yourself or others, read and understand the Safety and operating instruction before installing, operating, repairing, maintaining, or changing accessories on the machine.

Post this Safety and operating instruction at work locations, provide copies to employees, and make sure that everyone reads the Safety and operating instruction before operating or servicing the machine. For professional use only.

In addition, the operator or the operator's employer must assess the specific risks that may be present as a result of each use of the machine.

Save all warnings and instructions for future reference.

Safety signal words

The safety signal words Danger, Warning and Caution have the following meanings:

DANGER	Indicates a hazardous situation which, if not avoided, will result in death or serious injury.
WARNING	Indicates a hazardous situation which, if not avoided, could result in death or serious injury.
CAUTION	Indicates a hazardous situation which, if not avoided, could result in minor or moderate injury.

Personal precautions and qualifications

Only qualified and trained persons may operate or maintain the machine. They must be physically able to handle the bulk, weight, and power of the tool. Always use your common sense and good judgement.

Personal protective equipment

Always use approved protective equipment. Operators and all other persons in the working area must wear protective equipment, including at a minimum:

- Protective helmet
- Hearing protection
- Impact resistant eye protection with side protection
- Respiratory protection when appropriate
- Protective gloves
- Proper protective boots
- Appropriate work overall or similar clothing (not loose-fitting) that covers your arms and legs.

Drugs, alcohol or medication

▲ WARNING Drugs, alcohol or medication

Drugs, alcohol or medication may impair your judgment and powers of concentration. Poor reactions and incorrect assessments can lead to severe accidents or death.

- ▶ Never use the machine when you are tired or under the influence of drugs, alcohol or medication.



- ▶ No person who is under the influence of drugs, alcohol or medication may operate the machine.

Installation, precautions

⚠ **WARNING Ejected working tool**

If the tool retainer on the machine is not in a locked position, the working tool can be ejected with force, which can cause personal injury.

- ▶ Always stop the machine before changing the working tool or accessories.
- ▶ Never point the working tool at yourself or anyone else.
- ▶ Make sure that the working tool is fully inserted and the tool retainer is in a locked position before the machine is started.
- ▶ Check the lock function by pulling the working tool outwards powerfully.

⚠ **WARNING Moving or slipping working tool**

An incorrect dimension of the working tool's shank can result in that the tool is lost or is slipping out during operation. Risk of severe injury or crushed hands and fingers.

- ▶ Check that the working tool has the shank length and dimensions that the machine is intended for.
- ▶ Never use a working tool without a collar.

Operation, precautions

⚠ **WARNING Overheating hazard**

The machine may overheat if the cooling air inlet is covered. This can cause serious damage to the machine and/or the operator.

- ▶ Never block or cover the cooling air inlet.

⚠ **DANGER Explosion hazard**

If a warm working tool or exhaust pipe comes into contact with explosives, an explosion could occur. During operating with certain materials, sparks and ignition can occur. Explosions will lead to severe injuries or death.

- ▶ Never operate the machine in any explosive environment.
- ▶ Never use the machine near flammable materials, fumes or dust.
- ▶ Make sure that there are no undetected sources of gas or explosives.

- ▶ Avoid contact with the warm exhaust pipe or the bottom of the machine.

⚠ **DANGER Fuel hazard**

The fuel is extremely flammable and petrol fumes can explode when ignited, causing serious injury or death.

- ▶ Protect your skin from contact with the fuel. If fuel has penetrated the skin, consult a qualified health professional.
- ▶ Never remove the filler cap, and never fill the fuel tank when the machine is hot.
- ▶ Always fill the fuel (environmental petrol also) outdoors or in a well ventilated place.
- ▶ Mix the fuel and fill the fuel tank outdoors or in a clean and well ventilated place, free from sparks and open flames. Fill the fuel tank at least ten meters (30 feet) from the place where the machine is to be used.
- ▶ Release the filler cap slowly to let pressure escape.
- ▶ Never overfill the fuel tank.
- ▶ Make sure the filler cap is screwed on when the machine is used.
- ▶ Avoid spilling fuel on the machine, wipe off any spilled fuel.
- ▶ Check regularly for fuel leaks. Never use the machine if it is leaking fuel.
- ▶ Never use the machine in the proximity of material that can generate sparks. Remove all hot or spark-generating devices before starting the machine.
- ▶ Never smoke when filling the fuel tank or when working with the machine or servicing it.
- ▶ Only store fuel in a container that is specially constructed and approved for the purpose.
- ▶ Consumed petrol and oil containers must be taken care of and returned to the retailer.
- ▶ Never use your fingers to check for fluid leaks.

⚠ **WARNING Unexpected movements**

The working tool is exposed to heavy strains when the machine is used. The working tool may break due to fatigue after a certain amount of use. If the working tool breaks or gets stuck, there may be sudden and unexpected movement that can cause injuries. Furthermore, losing your balance or slipping may cause injury.

- ▶ Make sure that you always keep a stable position with your feet as far apart as your shoulder width, and keeping a balanced body weight.

- ▶ Always inspect the equipment prior to use. Never use the equipment if you suspect that it is damaged.
- ▶ Make sure that the handles are clean and free of grease and oil.
- ▶ Keep your feet away from the working tool.
- ▶ Stand firmly and always hold on to the machine with both hands.
- ▶ Never start the machine when it is lying on the ground.
- ▶ Never 'ride' on the machine with one leg over the handle.
- ▶ Never strike or abuse the equipment.
- ▶ Check regularly for wear on the working tool, and check whether there are any signs of damage or visible cracks.
- ▶ Pay attention and look at what you are doing.

▲ WARNING Dust and fume hazard

Dusts and/or fumes generated or dispersed when using the machine may cause serious and permanent respiratory disease, illness, or other bodily injury (for example, silicosis or other irreversible lung disease that can be fatal, cancer, birth defects, and/or skin inflammation).

Some dusts and fumes created by drilling, breaking, hammering, sawing, grinding and other construction activities contain substances known to the State of California and other authorities to cause respiratory disease, cancer, birth defects, or other reproductive harm. Some examples of such substances are:

- Crystalline silica, cement, and other masonry products.
- Arsenic and chromium from chemically-treated rubber.
- Lead from lead-based paints.

Dust and fumes in the air can be invisible to the naked eye, so do not rely on eye sight to determine if there is dust or fumes in the air.

To reduce the risk of exposure to dust and fumes, do all of the following:

- ▶ Perform site-specific risk assessment. The risk assessment should include dust and fumes created by the use of the machine and the potential for disturbing existing dust.
- ▶ Use proper engineering controls to minimize the amount of dust and fumes in the air and to minimize build-up on equipment, surfaces, clothing, and body parts. Examples of controls include: exhaust ventilation and dust collection systems, water sprays, and wet drilling. Control dusts and fumes at the source where possible.

Make sure that controls are properly installed, maintained and correctly used.

- ▶ Wear, maintain and correctly use respiratory protection as instructed by your employer and as required by occupational health and safety regulations. The respiratory protection must be effective for the type of substance at issue (and if applicable, approved by relevant governmental authority).
- ▶ Work in a well ventilated area.
- ▶ If the machine has an exhaust, direct the exhaust so as to reduce disturbance of dust in a dust filled environment.
- ▶ Operate and maintain the machine as recommended in the operating and safety instructions.
- ▶ Select, maintain and replace consumables/insertion tools/ other accessories as recommended in the operating and safety instructions. Incorrect selection or lack of maintenance of consumables/ inserted tools/ other accessories may cause an unnecessary increase in dust or fumes.
- ▶ Wear washable or disposable protective clothes at the worksite, and shower and change into clean clothes before leaving the worksite to reduce exposure of dust and fumes to yourself, other persons, cars, homes, and other areas.
- ▶ Avoid eating, drinking, and using tobacco products in areas where there is dust or fumes.
- ▶ Wash your hands and face thoroughly as soon as possible upon leaving the exposure area, and always before eating, drinking, using tobacco products, or making contact with other persons.
- ▶ Comply with all applicable laws and regulations, including occupational health and safety regulations.
- ▶ Participate in air monitoring, medical examination programs, and health and safety training programs provided by your employer or trade organizations and in accordance with occupational health and safety regulations and recommendations. Consult with physicians experienced with relevant occupational medicine.
- ▶ Work with your employer and trade organization to reduce dust and fume exposure at the worksite and to reduce the risks. Effective health and safety programs, policies and procedures for protecting workers and others against harmful exposure to dust and fumes should be established and implemented based

on advice from health and safety experts. Consult with experts.

- ▶ Residues of hazardous substances on the machine can be a risk. Before undertaking any maintenance on the machine, clean it thoroughly.

▲ **DANGER Exhaust gas hazard**

The exhaust gas from the machine's combustion engine contains carbon monoxide which is poisonous, and chemicals known to the State of California and other authorities to cause cancer, birth defects, or other reproductive harm. Inhalation of exhaust fumes can cause serious injury, illness, or death.

- ▶ Never inhale exhaust fumes.
- ▶ Never operate the machine indoors or in a poorly ventilated area.
- ▶ Never stand in a deep hole, ditch, or similar surrounding during operating.

▲ **WARNING Projectiles**

Failure of the work piece, of accessories, or even of the machine itself may generate high velocity projectiles. During operating, splinters or other particles from the working material may become projectiles and cause personal injury by striking the operator or other persons. To reduce these risk:

- ▶ Use approved personal protective equipment and safety helmet, including impact resistant eye protection with side protection.
- ▶ Make sure that no unauthorised persons trespass into the working zone.
- ▶ Keep the workplace free from foreign objects.
- ▶ Ensure that the work piece is securely fixed.

▲ **WARNING Splinters hazard**

Using the working tool as a hand struck tool can result in splinters hitting the operator and can cause personal injury.

- ▶ Never use a working tool as a hand struck tool. They are specifically designed and heat-treated to be used only in a machine.

▲ **WARNING Slipping, tripping and falling hazards**

There is a risk of slipping, tripping or falling, for example tripping on hoses or on other objects. Slipping, tripping or falling can cause injury. To reduce this risk:

- ▶ Always make sure that no hose or other object is in your way or in any other person's way.

- ▶ Always make sure you are in a stable position with your feet as far apart as your shoulder width and keeping a balanced body weight.

▲ **WARNING Motion hazards**

When using the machine to perform work-related activities, you may experience discomfort in the hands, arms, shoulders, neck, or other parts of the body.

- ▶ Adopt a comfortable posture while maintaining secure footing and avoiding awkward off-balanced postures.
- ▶ Changing posture during extended tasks may help avoid discomfort and fatigue.
- ▶ In case of persistent or recurring symptoms, consult a qualified health professional.

▲ **WARNING Vibration hazards**

Normal and proper use of the machine exposes the operator to vibration. Regular and frequent exposure to vibration may cause, contribute to, or aggravate injury or disorders to the operator's fingers, hands, wrists, arms, shoulders and/or nerves and blood supply or other body parts, including debilitating and/or permanent injuries or disorders that may develop gradually over periods of weeks, months, or years. Such injuries or disorders may include damage to the blood circulatory system, damage to the nervous system, damage to joints, and possibly damage to other body structures.

If numbness, persistent recurring discomfort, burning sensation, stiffness, throbbing, tingling, pain, clumsiness, weakened grip, whitening of the skin, or other symptoms occur at any time, when operating the machine or when not operating the machine, stop operating the machine, tell your employer and seek medical attention. Continued use of the machine after the occurrence of any such symptom may increase the risk of symptoms becoming more severe and/or permanent.

Operate and maintain the machine as recommended in these instructions, to prevent an unnecessary increase in vibration.

The following may help to reduce exposure to vibration for the operator:

- ▶ Let the machine do the job. Use a minimum hand grip consistent with proper control and safe operation. Use the correct feed force on the machine. Avoid pressing too hard.
- ▶ If the machine has vibration absorbing handles, keep them in a central position, avoid pressing the handles into the end stops.
- ▶ When the percussion mechanism is activated, the only body contact with the machine you

should have your hands on the handle or handles. Avoid any other contact, for example supporting any part of the body against the machine or leaning onto the machine trying to increase the feed force. It is also important not to keep the start and stop device engaged while extracting the tool from the work surface.

- ▶ Make sure that the inserted tool is well-maintained (including sharpness, if a cutting tool), not worn out, and of the proper size. Working tools that are not well-maintained, or that are worn out, or that are not of the proper size result in longer time to complete a task (and a longer period of exposure to vibration) and may result in or contribute to higher levels of vibration exposure.
- ▶ Immediately stop working if the machine suddenly starts to vibrate strongly. Before resuming the work, find and remove the cause of the increased vibrations.
- ▶ Never grab, hold or touch the inserted tool when using the machine.
- ▶ Participate in health surveillance or monitoring, medical exams and training programs offered by your employer and when required by law.
- ▶ When working in cold conditions wear warm clothing and keep hands warm and dry.
- ▶ The exhaust air is strongly chilled and shall not make contact with the operator. Always direct the exhaust air away from hands and body.

See the "Noise and vibration declaration statement" for the machine, including the declared vibration values. This information can be found at the end of these Safety and operating instructions.

⚠ DANGER Electrical hazard

The machine is not electrically insulated. If the machine comes into contact with electricity, serious injuries or death may result.

- ▶ Never operate the machine near any electric wire or other source of electricity.
- ▶ Make sure that there are no concealed wires or other sources of electricity in the working area.

⚠ WARNING Concealed object hazard

During operating, concealed wires and pipes constitute a danger that can result in serious injury.

- ▶ Check the composition of the material before operating.
- ▶ Watch out for concealed cables and pipes for example electricity, telephone, water, gas and sewage lines etc.

- ▶ If the inserted tool seems to have hit a concealed object, switch off the machine immediately.
- ▶ Make sure that there is no danger before continuing.

⚠ WARNING Involuntary start

Involuntary start of the machine may cause injury.

- ▶ Keep your hands away from the start and stop device until you are ready to start the machine.
- ▶ Learn how the machine is switched off in the event of an emergency.

⚠ WARNING Noise hazard

High noise levels can cause permanent and disabling hearing loss and other problems such as tinnitus (ringing, buzzing, whistling, or humming in the ears). To reduce risks and prevent an unnecessary increase in noise levels:

- ▶ Risk assessment of these hazards and implementation of appropriate controls is essential.
- ▶ Operate and maintain the machine as recommended in these instructions.
- ▶ Select, maintain and replace the working tool as recommended in these instructions.
- ▶ If the machine has a silencer, check that it is in place and in good working condition.
- ▶ Always use hearing protection.
- ▶ Use damping material to prevent work pieces from 'ringing'.

⚠ WARNING Unstable position hazard

During operation of the machine, there is a risk for falling, tripping and/or coming in contact with the working tool, which can cause injury. This risk increases if you work in an unstable position or on any unstable ground, object or surface. To reduce this risk:

- ▶ Never work in an unstable position.
- ▶ Always make sure you are in a stable position with your feet as far apart as your shoulder width and keeping a balanced body weight.
- ▶ Never stand on any unstable ground, objects or surfaces.



▲ WARNING Slippery machine surface hazard

There is a risk that the machine (for example, the handle and other surfaces) is slippery due to grease, oil, or other substances. If the machine is slippery, there is a risk that you might lose your grip, drop the machine, and/or come in contact with the working tool during operation of the machine. Any such event can cause injury. To reduce this risk:

- ▶ Always make sure that the handles and other gripping surfaces of the machine are not slippery.
- ▶ Always make sure that the handles and other gripping surfaces are free from grease and oil.

Maintenance, precautions**▲ WARNING Machine modification**

Any machine modification may result in bodily injuries to yourself or others.

- ▶ Never modify the machine. Modified machines are not covered by warranty or product liability.
- ▶ Always use original parts, cutting blades/working tools, and accessories.
- ▶ Change damaged parts immediately.
- ▶ Replace worn components in good time.

▲ CAUTION High temperature

The machine's front cover, exhaust pipe, and bottom become hot during operation. Touching them can lead to burns.

- ▶ Never touch a hot front cover.
- ▶ Never touch the hot exhaust pipe.
- ▶ Never touch the bottom of the machine when it is hot.
- ▶ Wait until the front cover, exhaust pipe, and bottom of the machine has cooled down before carrying out maintenance work.

▲ CAUTION Hot working tool

The tip of the working tool can become hot and sharp when used. Touching it can lead to burns and cuts.

- ▶ Never touch a hot or sharp working tool.
- ▶ Wait until the working tool has cooled down before carrying out maintenance work.

Storage, precautions

- ◆ Keep the machine and tools in a safe place, out of the reach of children and locked up.

Overview

To reduce the risk of serious injury or death to yourself or others, read the Safety instructions section found on the previous pages of this manual before operating the machine.

Design and function

Cobra TTe is designed for tie tamping and can also be used for medium demolition of material such as asphalt.

The petrol breaker is designed for vertical use only. No other use is permitted.

The machine can be operated with Alkylat petrol with 2 stroke oil 2% (50:1), which is a petrol that is better for the environment, the motor, and the operator's health.

To choose the correct working tool, check the tool shank dimension specified on the machine, and see the spare parts list.

Main parts

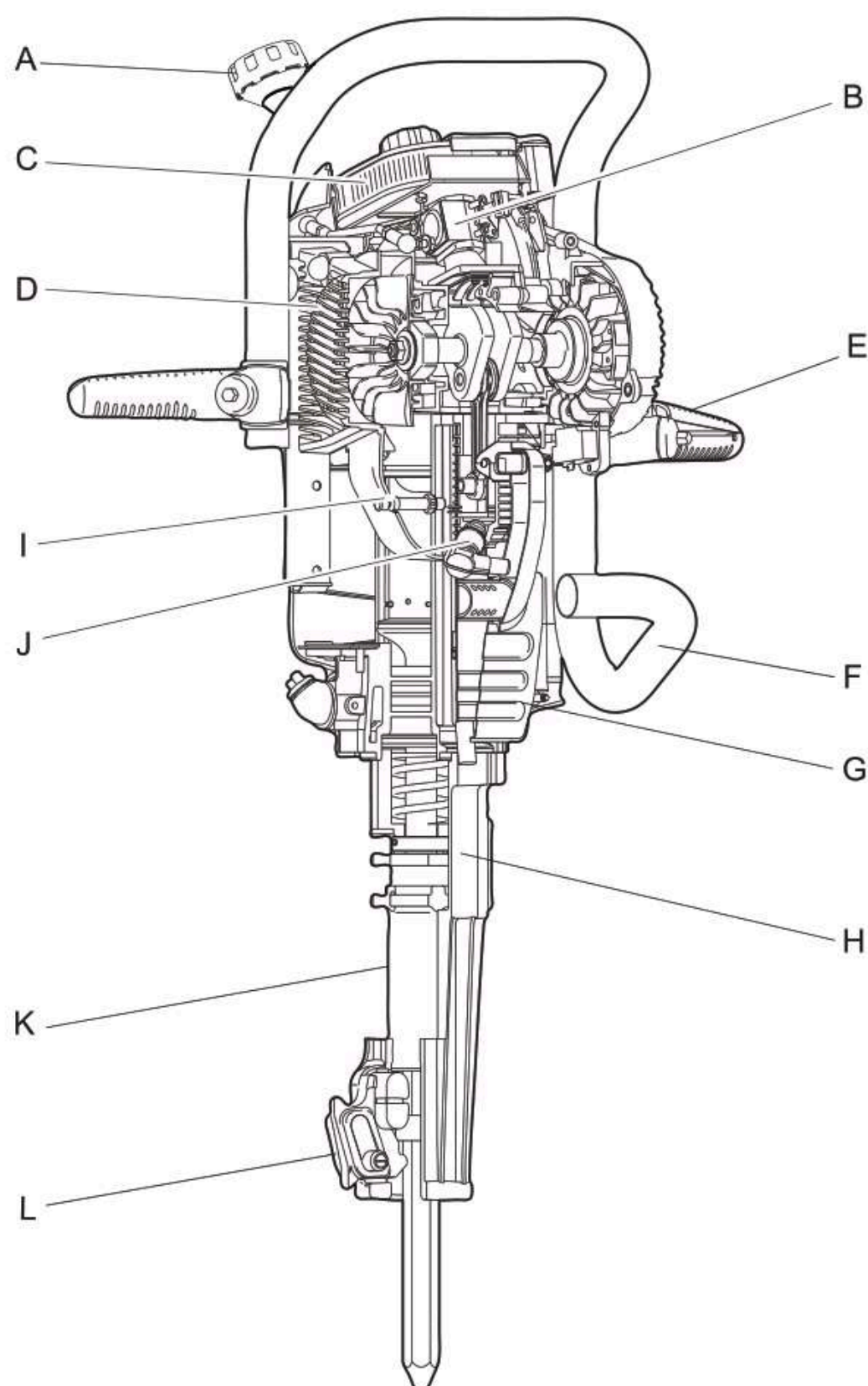

- A. Fuel filler cap
- B. Carburettor

- C. Air filter
- D. Fan cover / Cooling air inlet
- E. Throttle lever
- F. Fuel tank
- G. Silencer
- H. Breaker housing
- I. Decompression valve
- J. Spark plug
- K. Tool chuck
- L. Tool retainer

Labels

The machine is fitted with labels containing important information about personal safety and machine maintenance. The labels must be in such condition that they are easy to read. New labels can be ordered from the spare parts list.

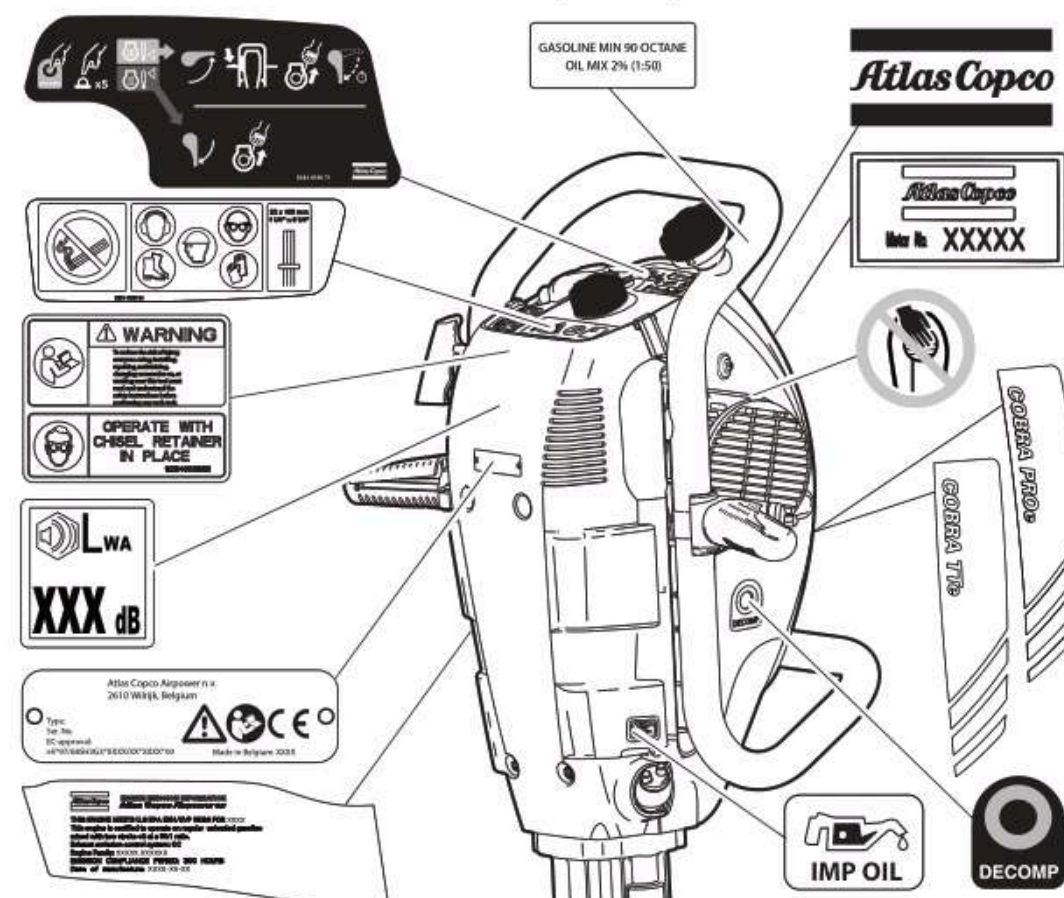

Data plate

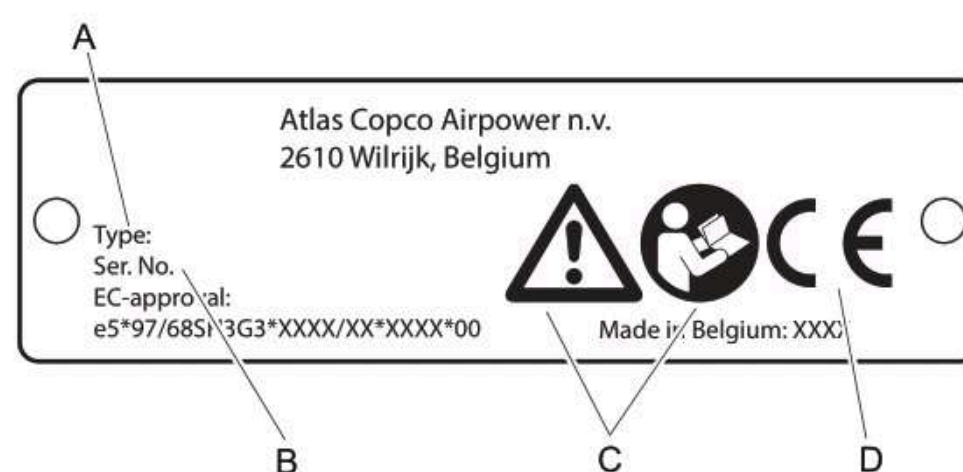

- A. Machine type
- B. Serial number
- C. The warning symbol together with the book symbol means that the user must read the safety and operating instructions before the machine is used for the first time.
- D. The CE symbol means that the machine is EC-approved. See the EC Declaration of

Conformity which is delivered with the machine for more information.

Noise level label

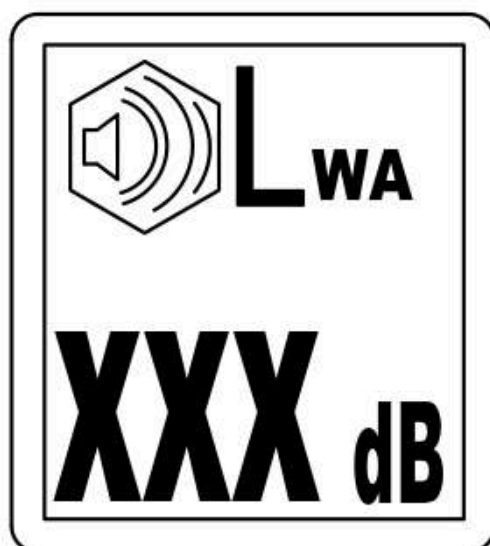

The label indicates the guaranteed noise level corresponding to EC-directive 2000/14/EC. See "Technical data" for accurate noise level.

Overheating hazard label



The machine may overheat if the cooling air inlet is covered. This can cause serious damage to the machine and/or the operator. Never block or cover the cooling air inlet.

Warning label

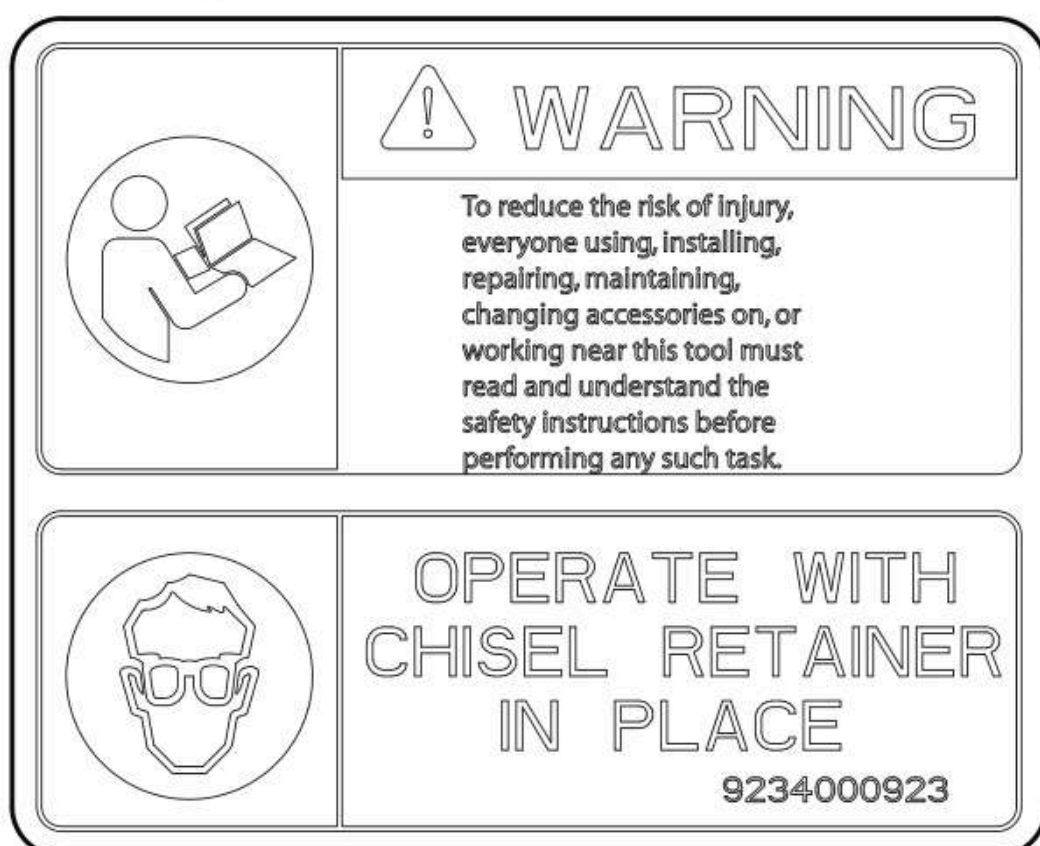

To reduce the risk of injury, everyone using, installing, repairing, maintaining, changing accessories on, or working near this tool must read and understand the safety instructions before performing any such task.

Operate with chisel retainer in place.

Emission compliance label



Emissions compliance period referred to on the label indicates the number of operating hours for which the engine has been shown to meet Federal emissions requirements.

Transport

⚠ WARNING Fuel hazard

The fuel (petrol and oil) is extremely flammable and petrol fumes can explode when ignited, causing serious injury or death.

- ▶ Empty the tank before transport.

Installation

Fuel

Environmental petrol

We recommend the use of premixed alkylate or environmental petrol mixed with two-stroke oil 2% (50:1).

NOTICE The machine is equipped with a two-stroke engine and must always be run using a mixture of petrol and two-stroke oil. It is important to accurately measure the amount of oil to be mixed to ensure that the correct mixture is obtained.

Two-stroke oil

The fuel is petrol with a 2% oil mixture (one part oil to 50 parts petrol).

For the best lubricating results use Atlas Copco's environmentally friendly two-stroke oil, which has been specially developed for Atlas Copco's petrol engine hammering and rock-drilling machines.

If Atlas Copco's two-stroke oil is not available, use a high quality two-stroke oil for air-cooled engines (not two-stroke oil for outboard engines). Contact your local Atlas Copco representative for advice on the correct two-stroke oil.

Mixing the petrol and oil

Always mix the petrol and oil in a clean petrol can. First add the oil and then the correct amount of petrol. Then shake the can thoroughly. Shake the can before every refilling.

NOTICE During long term storage of two-stroke mixture, the oil and petrol can separate. Never mix more fuel than you intend to use within two weeks.

Filling

⚠ **WARNING Fuel hazard**

The fuel (petrol and oil) is extremely flammable and petrol fumes can explode when ignited, causing serious injury or death.

- ▶ Protect your skin from contact with the fuel.
- ▶ Never remove the filler cap and do not fill the fuel tank when the machine is hot.
- ▶ Never smoke when filling the fuel tank or when working with the machine or servicing it.
- ▶ Avoid spilling fuel and wipe off any fuel spilled on the machine.
- ▶ Fill the fuel tank outdoors or in a clean and well ventilated place, free from sparks and open flames.

Filling procedure

1. Stop the engine and let it cool down before filling the tank.
2. The machine must be in an upright position when filling it with fuel.

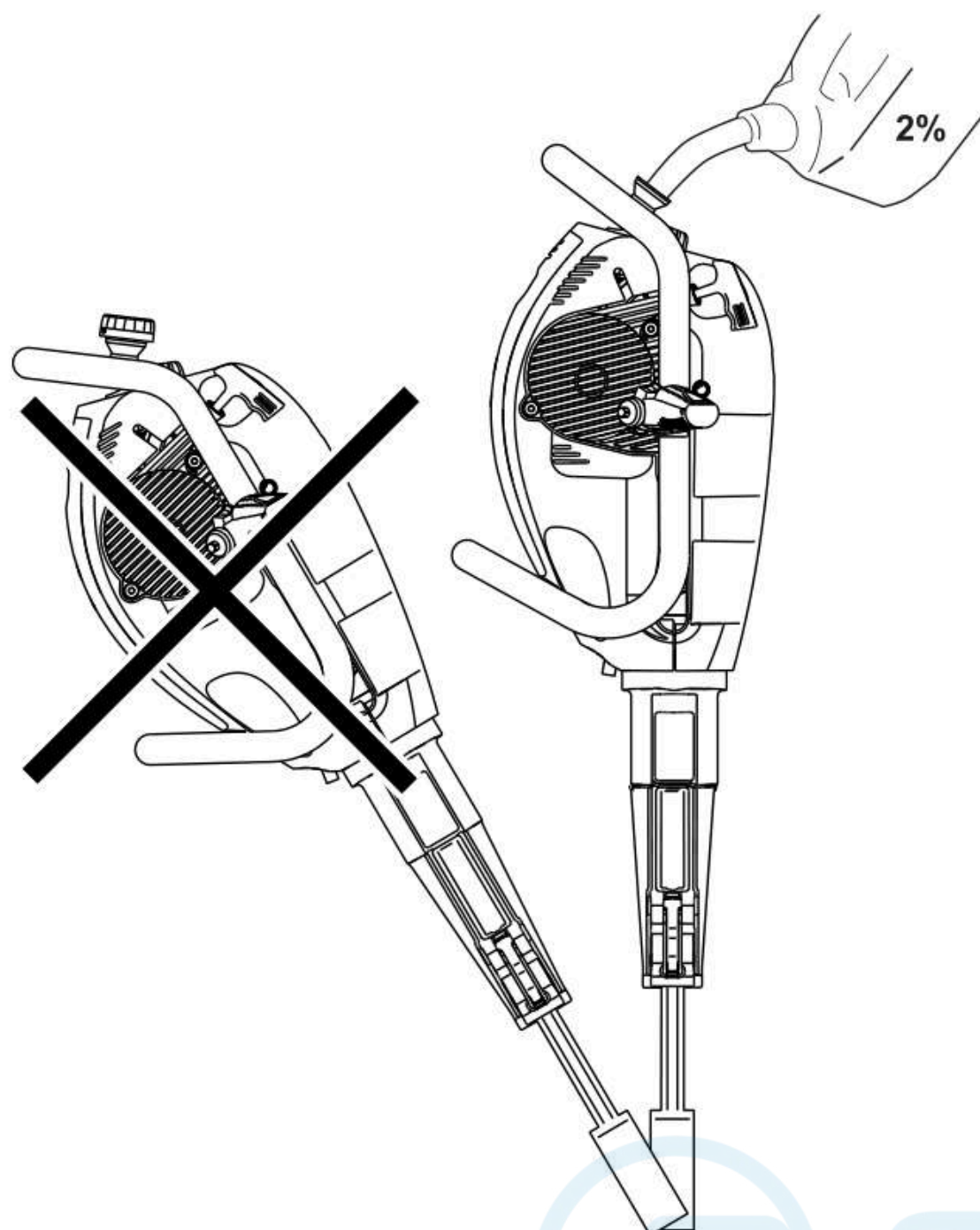

3. Release the filler cap slowly to let any pressure escape.
4. Never overfill the tank. It is possible due to the movement of the fuel within the tank to have fuel at a higher level than the tank cap, which can lead to a spillage of fuel if the tank cap is opened. This can be avoided by opening the tank cap, only when the machine is tilted and the tank cap is at the fuel tanks highest point.
5. Make sure that the filler cap is screwed on when the machine is used.

Working tool

⚠ CAUTION Hot working tool

The tip of the working tool can become hot and sharp when used. Touching it can lead to burns and cuts.

- ▶ Never touch a hot or sharp working tool.
- ▶ Wait until the working tool has cooled down before carrying out maintenance work.

NOTICE Never cool a hot working tool in water, it can result in brittleness and early failure.

Selecting the correct working tool

Selecting the correct working tool is a precondition for proper machine function. It is important to select a high quality working tool to avoid unnecessary machine damage.

Never use a working tool without a collar. Always use the correct working tool.

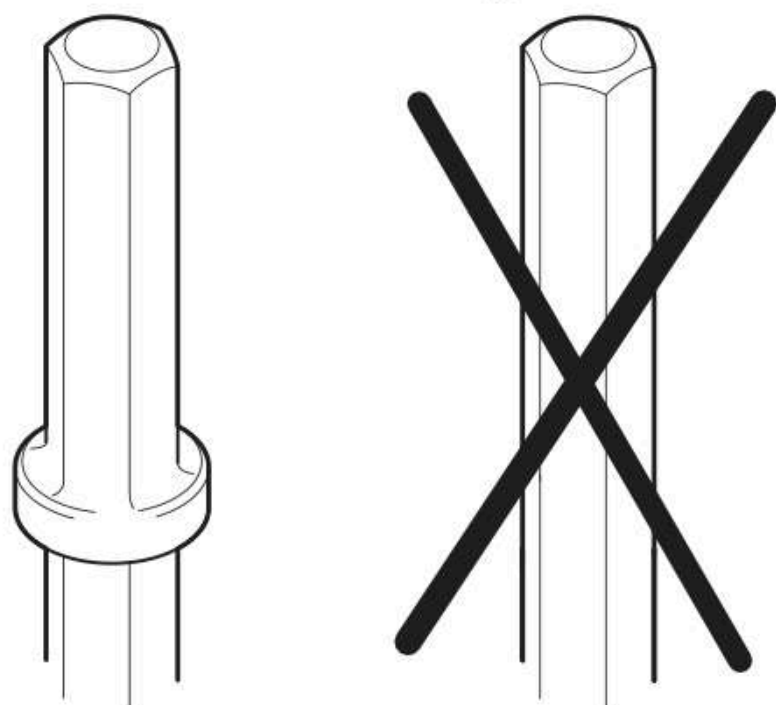

NOTICE Never use the machine directly on spikes or tent poles.

Recommended working tools are listed in the machine's spare parts list.

Narrow chisel

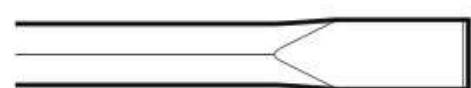

The narrow chisel is used for demolition and cutting work in concrete and other types of hard materials.

Moil point



The moil point is only used for making holes in concrete and other types of hard materials.

Wide bladed chisel

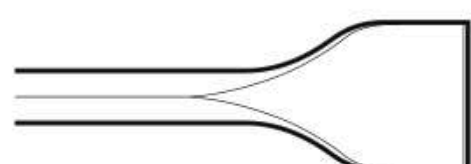

The wide bladed chisel is used in soft materials, such as asphalt and frozen ground.

Spiking tool

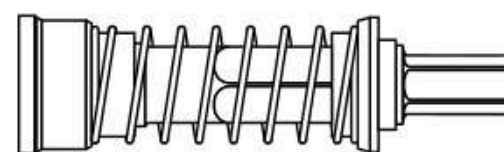

The spiking tool is used for spikes and tent poles in soft materials, such as asphalt and frozen ground.

⚠ WARNING Vibration hazard

Using inserted tools that do not fulfil the criteria mentioned below, will result in a longer time to complete a task, and may result in higher levels of vibration exposure. A worn tool will also cause increased working time.

- ▶ Make sure that the inserted tool is well-maintained, not worn out and of the proper size.
- ▶ Always use a sharp tool in order to work efficiently.

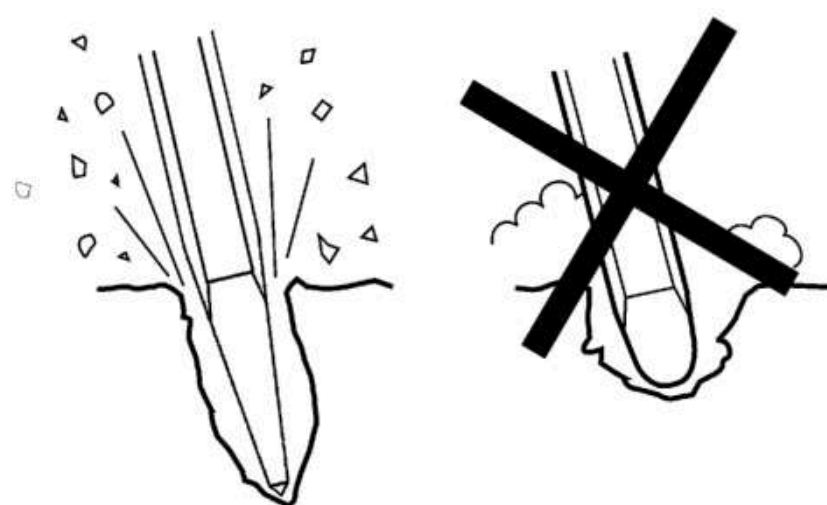

Checking for wear on the tool shank

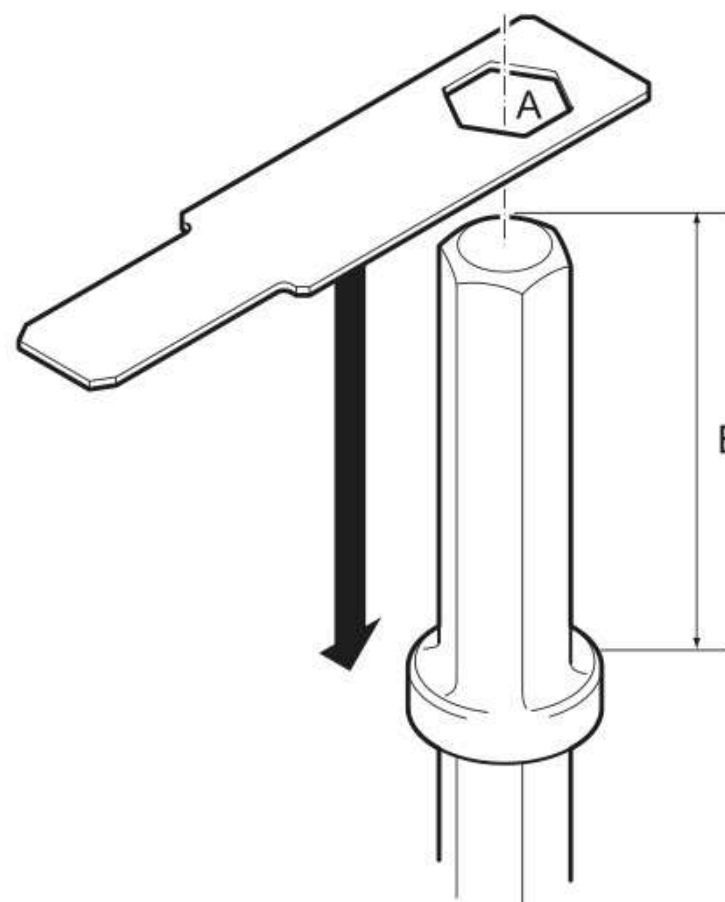

Use the gauge that corresponds to the working tool's shank dimension. See section "Technical data" for correct tool shank dimensions.

- Check if the gauge's hole (A) can be pushed down on the working tool's shank, this means that the shank is worn out and that the tool should be replaced.
- Check the length (B), that it is according to the ordered machine type.

Operation

⚠ **WARNING** Involuntary start

Involuntary start of the machine may cause injury.

- ▶ Keep your hands away from the start and stop device until you are ready to start the machine.
- ▶ Learn how the machine is switched off in the event of an emergency.

Start and stop

Cold start

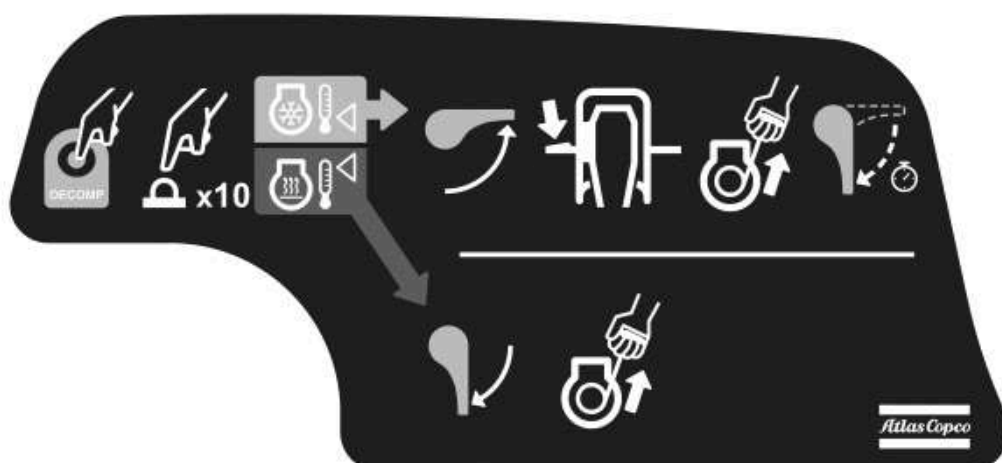

1. Remove the fuel cap and check the fuel level. Secure the fuel cap before start.
2. Press the decomp knob located at the right side of the front cover.
3. Pump at least ten times on the primer pump.
4. Close the choke by turning the choke control into upward position.
5. Press and hold the throttle lever.
6. Pull the starter handle. Never release the starter handle until it reaches the starter cover. If the machine starts but then stops. Press the decomp knob and adjust the choke to halfway position. Pull the starter handle.
7. Five seconds after the machine starts, put choke gradually into a downward position.
8. Let the engine run for 1-2 minutes with throttle lever slightly pressed before use. Full performance will be reached after approximately 5 minutes of use.

Warm start

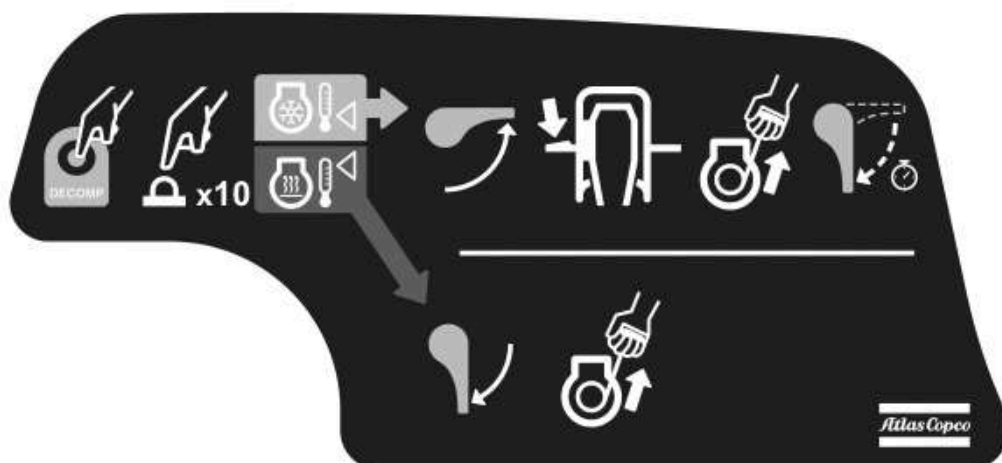

1. Remove the fuel cap and check the fuel level. Secure the fuel cap before start.

2. Press the decomp knob on the right side of the front cover.
3. Pump at least ten times on the primer pump.
4. Make sure that the choke is opened, the choke control must be in downward position.
5. Pull the starter handle. Never release the starter handle until it reaches the starter cover.

Stopping

- ◆ Stop the machine by pushing the stop button (on the left handle) forwards, until the engine stops.

Operating

Starting a cut

- ◆ Stand in a stable position with feet well away from the working tool.
- ◆ Press the machine against the working surface before starting.
- ◆ The impact unit is activated when the machine is pressed down and loaded. When the machine is lifted, the impact unit disengages automatically.
- ◆ The working speed of the machine is controlled via the throttle lever.
- ◆ Start collaring at such a distance from the edge that the machine is capable of breaking the material without levering.
- ◆ Never break off too large pieces. Adjust the breaking distance (A) so that the working tool does not fasten.

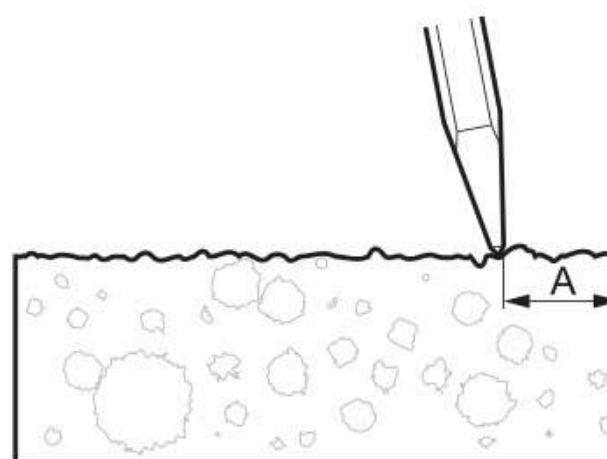

Breaking

- ◆ Never use the machine as a lever, the material must be broken by impact energy.
- ◆ If the tool fastens, never try to lift it by pulling on the top of the fuel tank.
- ◆ Check that the handle bar can move freely (up and down) without binding.
- ◆ Let the machine do the work. Never press too hard. The vibration absorbing handle must never be forced all the way to the bottom.
- ◆ The feed force must be adjusted so that the handle is pressed 'half way down'. This position

provides the best vibration damping and the best breaking force.

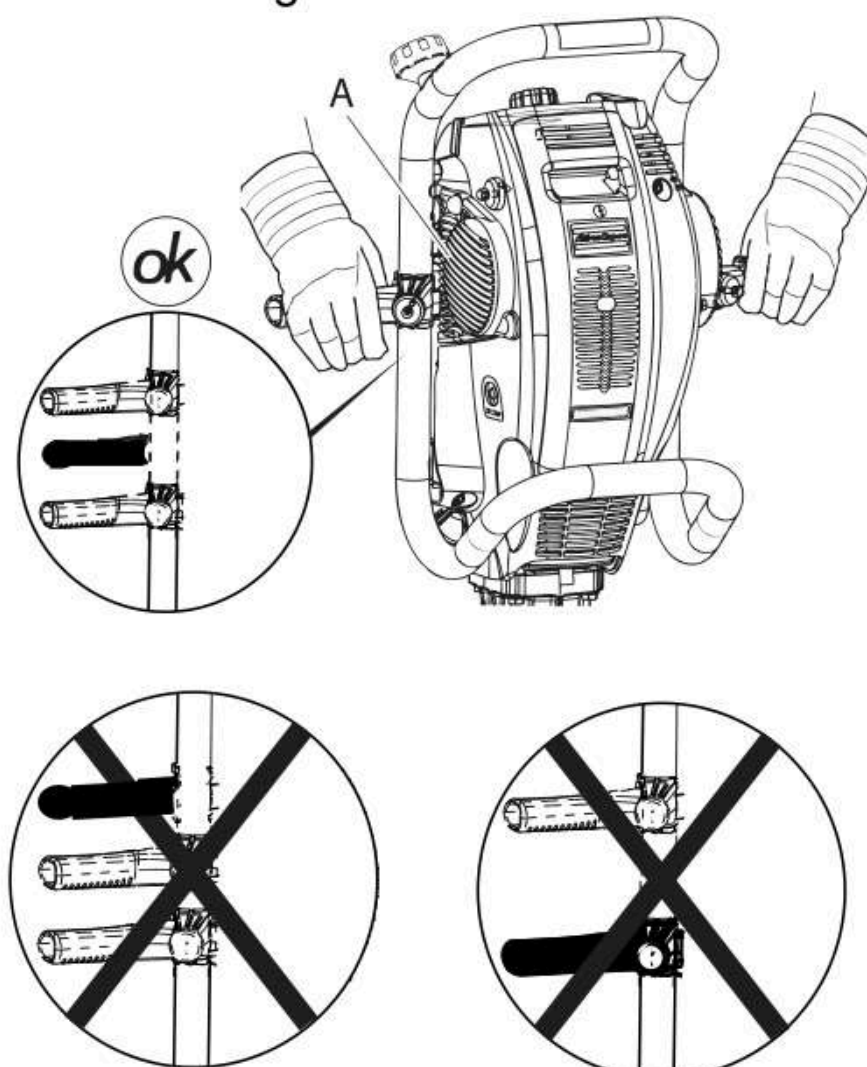

- ◆ Avoid working in extremely hard material such as granite and reinforcing iron, since such materials can cause strong vibrations.
- ◆ Never block or cover the cooling air inlet (A) during operation.
- ◆ Avoid idling; operation without a working tool and operation with the machine lifted.
- ◆ Release the throttle lever when the machine is lifted.

Breaking using special tools

For special applications such as asphalt cutting or digging the machine can be operated sideways as to line the working tool up in a specific direction. Never block or cover the cooling air inlet (A).

- ◆ As a first measure, hold the machine so that the air inlet faces away from you.
- ◆ As a second measure, under the condition that the air inlet is never blocked or covered, hold the machine so that the inlet faces towards you.

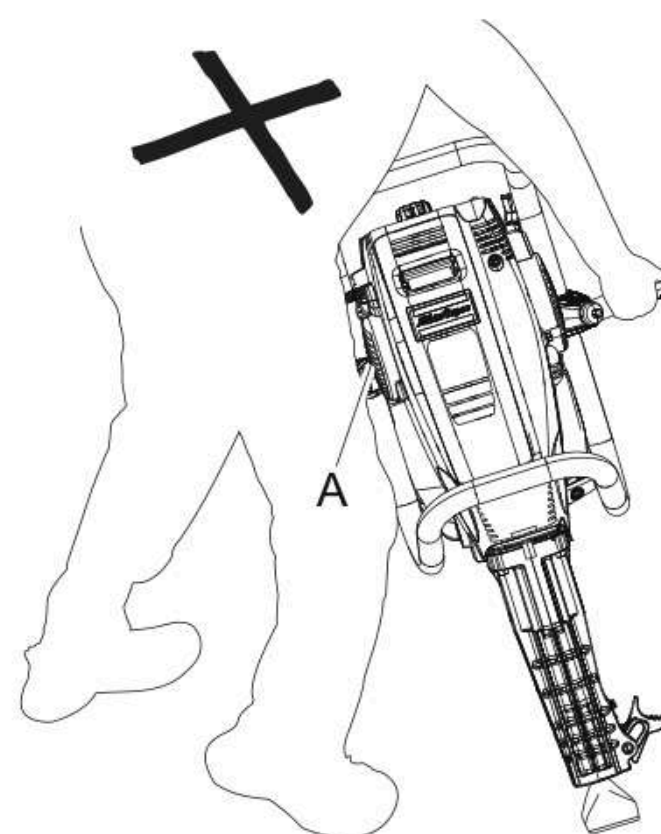
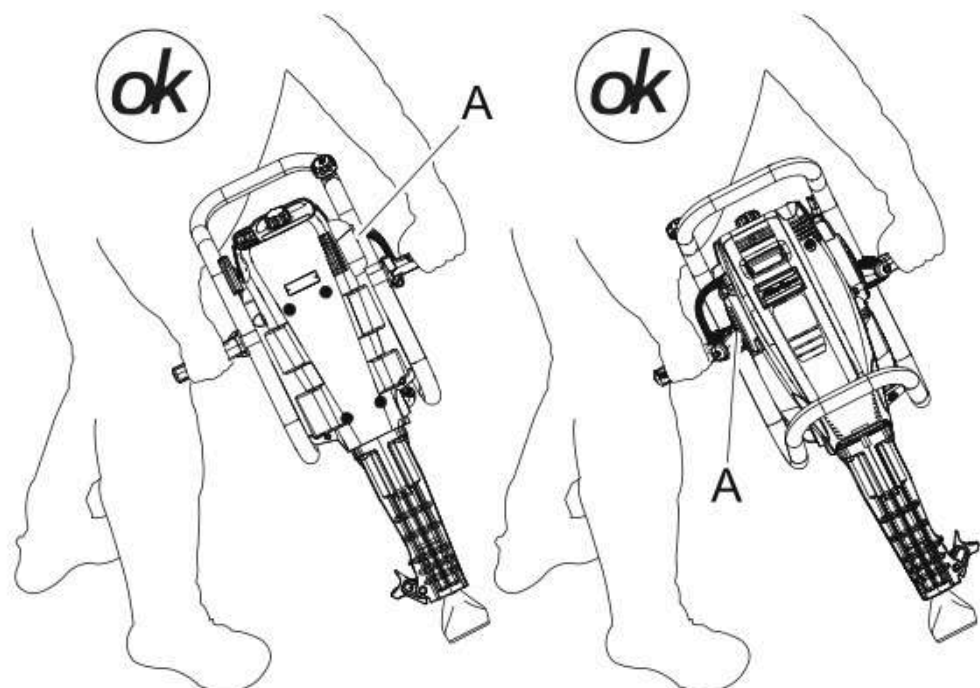

- ◆ It is also possible to rotate the working tool in the tool chuck instead of rotating the actual machine.

NOTICE To choose the correct working tool, check the tool shank dimension specified on the machine and see the spare parts list.

Breaking at high altitude

To get the best result when breaking at high altitude, do the following:

- ◆ Check that the air filter is in good condition.
- ◆ If necessary, lean the fuel mix by turning the main nozzle (A) clockwise.

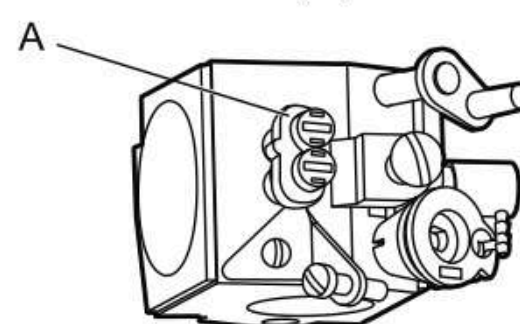

- ◆ When finished with operating at high altitude, turn back the main nozzle (A) to the default position.

Tie tamping

Cobra TTe is designed for tie tamping.

Tie tamping is used for local maintenance of railway tracks in an area up to 30 square meters. Tie tamping stabilizes the ballast under the sleepers.

To get the best result when tie tamping, do the following:

- ◆ Two operators must operate on each side of the sleeper. Operating on opposite sides will compress the ballast down and up, and fill all gaps and create stability.
- ◆ Lean the machine when operating. Do not operate in a straight angle, it will compress the ballast too deeply and reduce the stability.
- ◆ Operate for 2-3 seconds at one point before moving to another operating point. Operating

too long time at one point will press the ballast too deeply.

- ◆ Release the throttle lever when the machine is lifted.

When taking a break

- ◆ Stop the machine during breaks.
- ◆ During all breaks, put the machine away so that there is no risk for unintentional start.

Maintenance

Regular maintenance is a basic requirement for the continued safe and efficient use of the machine. Follow the maintenance instructions carefully.

- ◆ Before starting maintenance on the machine, clean it in order to avoid exposure to hazardous substances. See "Dust and fume hazard".
- ◆ Never use a pressure washer on the top cover or inside the breaker housing.

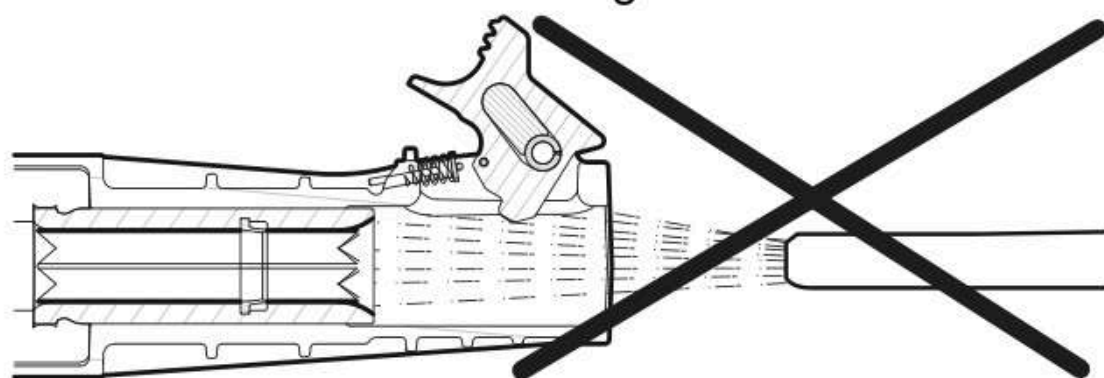

- ◆ Use only authorised parts. Any damage or malfunction caused by the use of unauthorised parts is not covered by warranty or product liability.
- ◆ When cleaning mechanical parts with solvent, comply with appropriate health and safety regulations and ensure there is satisfactory ventilation.
- ◆ For major repair or service of the machine, contact the nearest authorised workshop. Perform service at your nearest authorized workshop according to Atlas Copco's recommended service intervals. The service kits needed for each interval can be found in the Spare parts list.

Every day

Before undertaking any maintenance or changing the working tool, turn the machine off.

- ◆ Perform a general inspection and check that there are no leaks and no damage, and change if necessary.
- ◆ Check for damaged or loose wiring. If found, contact an authorised workshop.

- ◆ Check that the tool retainer is not worn and that it functions as it should. Never use the equipment if you suspect that it is damaged.
- ◆ Check for wear in the tool chuck.
- ◆ Check the working tool, make sure that it is sharp and not worn out. Check that the tool shank is clean.

- ◆ Replace worn components in good time.

In order to ensure that the machine remains within the stated vibration level values, the following checks must be performed:

Wear check

If a working tool with a worn shank is used, machine vibration will increase. Avoid such vibration by checking for shank wear before mounting the working tool on the machine.

- ◆ Use the shank gauge that corresponds to the dimension of the working tools shank. If the gauge can be inserted beyond point A in the tool chuck (point B) then the tool chuck must be replaced immediately.

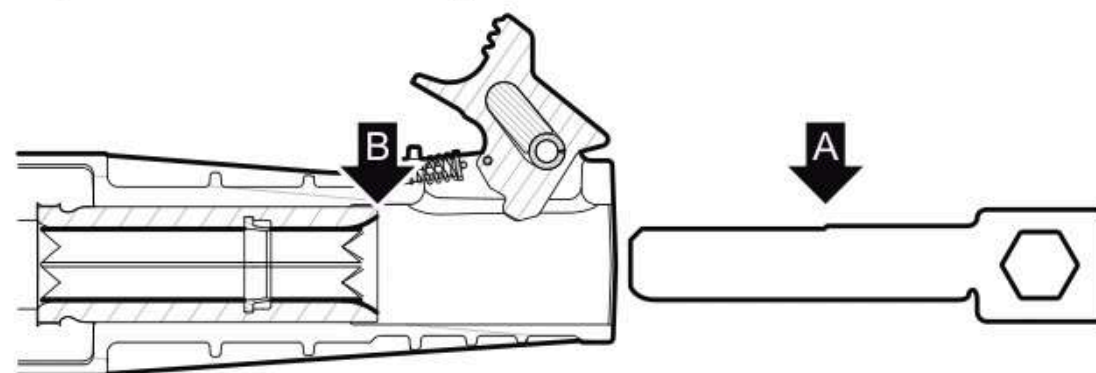

Air filter check

A clogged air filter will eventually cause damage to the engine. Check the air filter regularly.

1. Unscrew the air filter cover.
2. If the air filter is dirty, it must be replaced. Never wash the air filter.
3. Clean filter container.

Spark plug check

If the spark plug electrodes are very dirty or burned, replace the spark plug. The spark plug is placed under the service cover, mounted in the cylinder head. See the section "Main parts" for position of the spark plug.

Only use Champion RCJ8 and make sure that the electrode gap is 0.6-0.7 mm (0.024-0.028 in.) before fitting the spark plug. Tighten the spark plug using the correct tightening torque, see Spare parts list.

Hammer mechanism oil check

The machine has a natural oil consumption and the oil level in the impact unit should be checked every day. The machine must be upright when

performing the oil check. The oil level must be at the same height as the filling pipe. When filling, check that the sealing is undamaged and tighten properly.

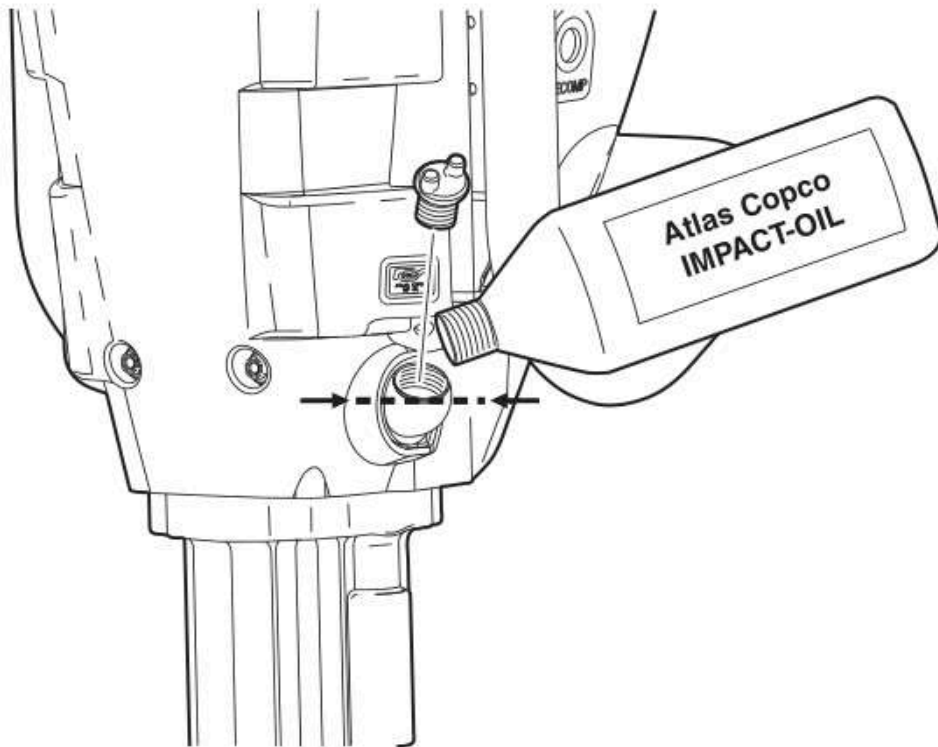

Use only Atlas Copco IMPACT-OIL.

Every month

Gearbox oil level check

1. The level in the gearbox is checked by unscrewing the oil plug using the spark plug wrench.
2. Fill the oil using an oil can to avoid spilling. The oil level is correct when it reaches the bottom of the filling hole when the machine is standing upright. The volume of the gearbox is 0.1 litre. Use only Atlas Copco IMPACT-OIL.

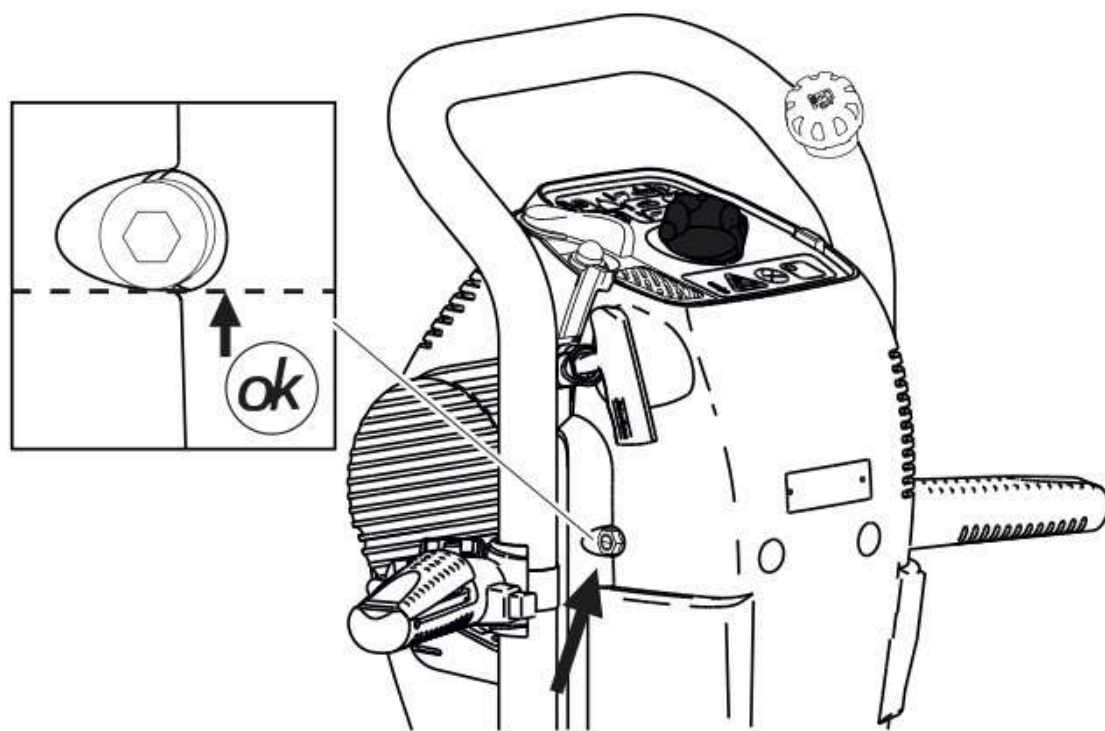

3. When finished filling, screw back the oil plug with a torque of 2 Nm.

Service

With continuous use of operation, leave the machine for service according to the following service interval:

- 3 months of continuous use
- 6 months of continuous use
- 12 months of continuous use

Service must for safety reasons be performed by authorised personnel at an authorised workshop.

Repair

Replacing the starter cord

Removing the old starter cord

1. Remove the starting mechanism.
2. Pull out about 40 cm (16 in.) of the cord.
3. Place the starter cord in the recess (A) in the pulley.

4. Rotate the pulley until all tension is released.
5. Remove the lock ring and lift out the pulley complete with spring and starter cord.

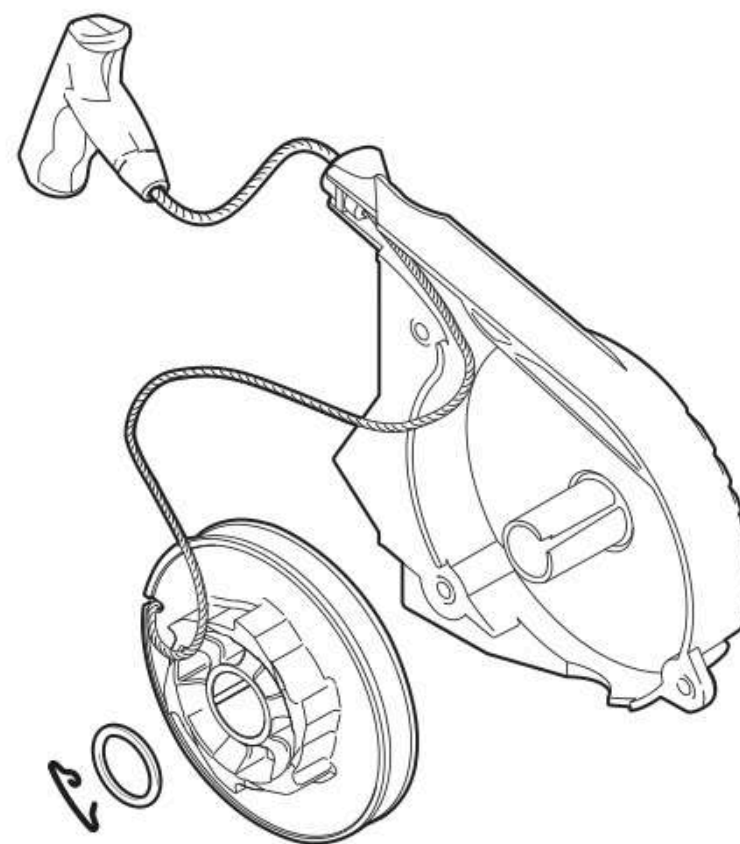

Fitting a new starter cord

6. **▲ WARNING Spring tension**
The starter spring may cause personal injury by striking the operator or other persons.
► Wear impact resistant eye protection with side protection and gloves.

Place the knot on the starter spring in the recess on the inside of the pulley and wind in the starter spring (anti-clockwise).

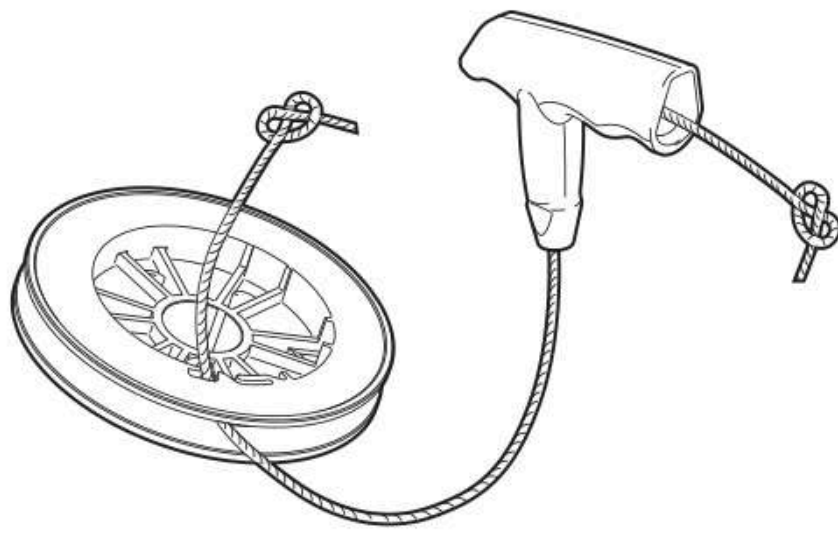

7. If the starter spring must be rewound, place the spring-hook in the pulley groove and wind on the spring anti-clockwise. If the spring must be replaced, position the spring-hook above the groove in the starter pulley. Leave the safety ring in place, press down the spring into the starter pulley.

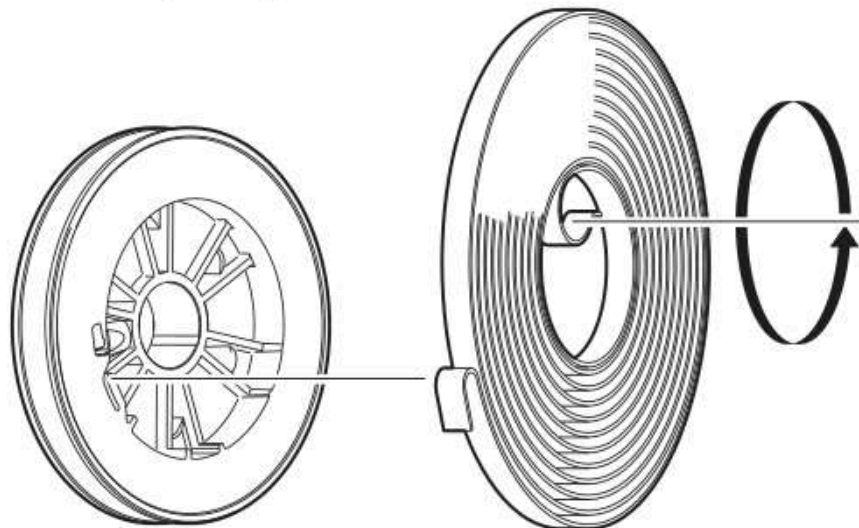

8. Wind up the starter cord onto the pulley leaving 5 cm (2 in.) of slack. Locate the end of the spring in the bushing groove, press the starter pulley onto the bushing. Replace the lock ring.

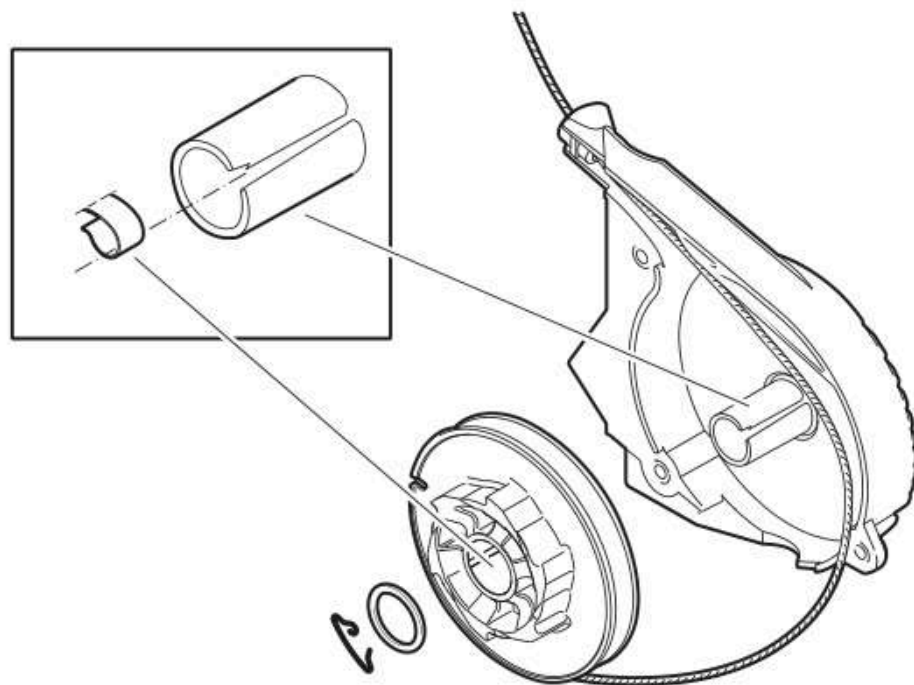

Pre-load the starting spring

9. Place the notch in the pulley edge in line with the starter cord guide and place the starter cord in the notch.
10. Fit the lock ring.

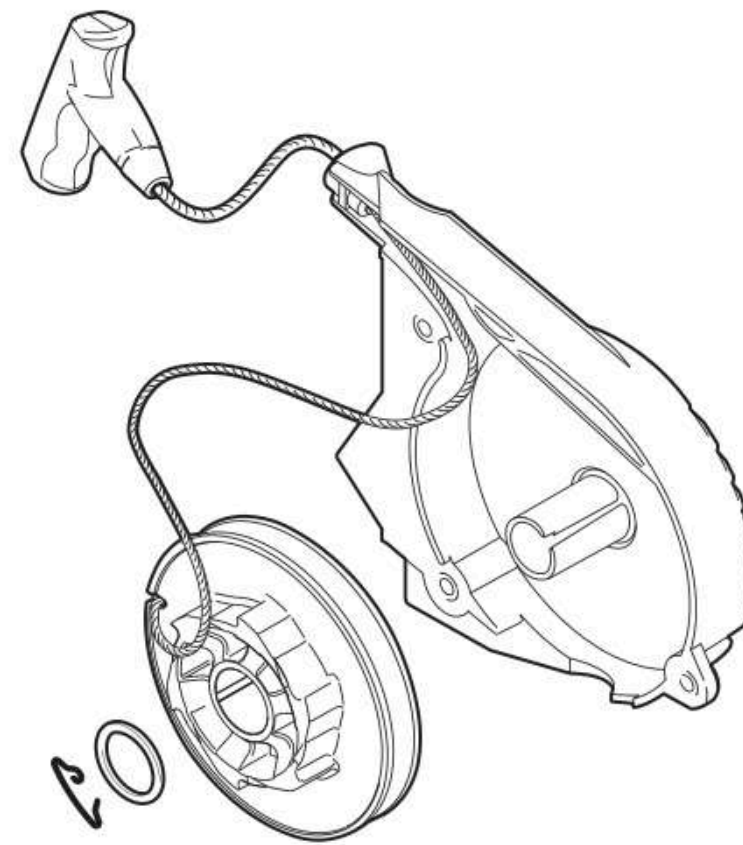

11. Rotate the pulley two turns anti-clockwise.
12. Release the starter cord slowly.
13. Pull on the starting handle, check the function.
14. Pull out the starter cable, at the same time grip the starter disc and check that it can be turned anticlockwise another half turn. If not, the spring has been over-tightened and is touching the bottom, the starter cable must therefore be loosened a turn.
15. Fit the starting mechanism.
16. Check the function.

Troubleshooting

If the petrol breaker does not start, has low power or runs unevenly, check the following points.

- ◆ Check that there is fuel in the tank.
- ◆ If a warm machine does not start, close the choke and try to restart the machine with full throttle.
- ◆ Check that the spark plug is undamaged and that the electrode gap is 0.6–0.7 mm (0.024–0.028 in.).
- ◆ Check that the air filter is clean and not clogged.
- ◆ Check that the working tool in use has the correct shank dimensions.
- ◆ Check that the cooling air inlet is not blocked or covered.

If the machine still does not function satisfactorily, contact an authorised workshop.

Storage

- ◆ Empty the tank before storing the machine.
- ◆ Check that the machine is properly cleaned before putting it away for storage.

- ◆ Store the machine in a dry place.
- ◆ We recommend to store the machine in a standing position. If stored in a lying position, the machine must be placed on the back cover.
- ◆ If the machine is stored on a stick and/or storage rack the insert must not exceed more than 155 mm (6.10 in.). If the maximum insert is exceeded the machine can be destroyed.
- ◆ Keep the machine and tools in a safe place, out of the reach of children and locked up.

Disposal

A used machine must be treated and disposed of in such a way that the greatest possible portion of the material can be recycled and any negative influence on the environment is kept as low as possible, and in respect to local restrictions.

Before a petrol driven machine is deposited it must be emptied and cleaned of all oil and petrol.

Remaining oil and petrol must be dealt with in a way that does not affect the environment.



Technical data

Products

Description	Part number	Tool shank size, mm (in.)
Cobra TTe	8318 0701 11	32 x 160 (1¼ x 6¼)
Cobra TTe US	8318 0701 13	32 x 152 (1¼ x 6)
Cobra TTe AUS	8318 0701 15	28 x 160 (1⅝ x 6¼)
Cobra TTe US	8318 0701 17	28 x 152 (1⅝ x 6)
Cobra TTe ISO	8318 0701 19	25 x 108 (1 x 4¼)
Cobra TTe US	8318 0701 43	25 x 108 (1 x 4¼)

Gearbox unit

	Cobra TTe
Oil type for gearbox	Atlas Copco IMPACT-OIL
Gearbox oil capacity, litres (oz)	0.1 (3.38)

Impact unit

	Cobra TTe
Impact energy	40 J at 1620 bpm
Lubrication	Impact mechanism through separate oil bath
Oil type for impact unit	Atlas Copco IMPACT-OIL
Oil capacity, litres (oz)	0.1 (3.38)
Oil consumption, litres/hour (oz/hour)	0.005 (0.17)

Machine data

	Cobra TTe	Cobra TTe 25 x 108 mm (1 x 4¼ in.)
Weight, kg (lb)	24 (53)	23 (51)
Length, mm (in.)	927 (36.5)	877 (36.3)
Depth, mm (in.)	331 (13)	331 (13)
Width across machine, mm (in.)	390 (15)	390 (15)
Width across handles, mm (in.)	320 (13)	320 (13)
Width with handles folded, mm (in.)	611 (24)	611 (24)
Fuel type	Alkylat or 90–100 octane unleaded petrol	
Fuel tank capacity, litres (oz)	1 (33.8)	1 (33.8)
Fuel mixture	2 % (1:50)	2 % (1:50)
Oil type	Atlas Copco two-stroke oil, or recommended two-stroke oil	
Fuel consumption, litres/hour (gallon/hour)	0.8 (0.176)	0.8 (0.176)
Engine type	1 cylinder, two-stroke	
Cooling system	Fan cooled	
Cylinder displacement (cc)	90	90
Power, kW (hp)	1.5 (2.0)	1.5 (2.0)
Full speed, loaded machine with tamping tool on bed of sand (r.p.m.)	6,500-7,000	6,500-7,000
Speed, unloaded machine, idling (r.p.m.)	1,800–2,200	1,800–2,200
Max. engine speed unloaded (r.p.m.)	7,500	7,500
Carburettor	Diaphragm carburettor	
Ignition system	Transistor type, breakerless with built in speed limitation	
Spark plug (recommended)	Champion RCJ8	
Spark plug gap, mm (in.)	0.6–0.7 (0.024–0.028)	0.6–0.7 (0.024–0.028)
Ambient temperature °C (°F)	-15 to +37 (5 to 98.6)	-15 to +37 (5 to 98.6)

Noise and vibration declaration statement

Guaranteed sound power level **L_w** according to EN ISO 3744 in accordance with directive 2000/14/EC.

Sound pressure level **L_p** according to EN ISO 11203.

Vibration value **A** and uncertainty **B** determined according to EN ISO 28927-10. See table "Noise and vibration data" for the values of A, B, etc.

These declared values were obtained by laboratory type testing in accordance with the stated directive or standards and are suitable for comparison with the declared values of other tools tested in accordance with the same directive or standards. These declared values are not suitable for use in risk assessments and values measured in individual work places may be higher. The actual exposure values and risk of harm experienced by an individual user are unique and depend upon the way the user works, in what material the machine is used, as well as upon the exposure time and the physical condition of the user, and the condition of the machine.

We, Atlas Copco Airpower, cannot be held liable for the consequences of using the declared values, instead of values reflecting the actual exposure, in an individual risk assessment in a work place situation over which we have no control.

This tool may cause hand-arm vibration syndrome if its use is not adequately managed. An EU guide to managing hand-arm vibration can be found at <http://www.humanvibration.com/humanvibration/EU/VIBGUIDE.html>

We recommend a programme of health surveillance to detect early symptoms which may relate to vibration exposure, so that management procedures can be modified to help prevent future impairment.

Noise and vibration data

	Noise		Vibration	
	Declared values		Declared values	
	Sound pressure	Sound power	Three axes values	
	EN ISO 11203	2000/14/EC	EN ISO 28927-10	
Type	L _p r=1m dB(A) rel 20µPa	L _w guaranteed dB(A) rel 1pW	A m/s ² value	B m/s ² spreads
Cobra TTe	96	109	3.8	1.1



EC Declaration of Conformity

EU Declaration of Conformity

We, Atlas Copco Airpower n.v., declare under our sole responsibility, that the product

Machine name	Motor Breaker
Machine type	
Serial number	

Which falls under the provisions of article 12.2 of the EC Directive 2006/42/EC on the approximation of the laws of the Member States relating to machinery, is in conformity with the relevant Essential Health and Safety Requirements of this directive.

The machinery complies also with the requirements of the following directives and their amendments as indicated.

Directive on the approximation of laws of the Member States relating to	Harmonized and/or Technical Standards used	Attachment
Machinery safety	2006/42/EC EN ISO 11148-4 : 2010	
Outdoor noise emission	2000/14/EC	X

The harmonized and the technical standards used are identified in the attachments hereafter
Atlas Copco Airpower n.v. is authorized to compile the technical file.

	Conformity of the specification to the directives	Conformity of the product to the specification and by implication to the directives
Issued by	Engineering	Manufacturing
Name	Vice president Research & Development	Vice president Manufacturing
Signature		
Date		
Place		Aartselaar, Belgium



Any unauthorized use or copying of the contents or any part thereof is prohibited. This applies in particular to trademarks, model denominations, part numbers, and drawings.

© Atlas Copco Airpower | 9800 1629 01 | 2018-01-01

